



UNIVERSITY OF CAMBRIDGE INTERNATIONAL EXAMINATIONS
International General Certificate of Secondary Education

CANDIDATE
NAME

CENTRE
NUMBER

--	--	--	--	--

CANDIDATE
NUMBER

--	--	--	--



PHYSICS

0625/33

Paper 3 Extended

May/June 2010

1 hour 15 minutes

Candidates answer on the Question Paper.

No Additional Materials are required.

READ THESE INSTRUCTIONS FIRST

Write your Centre number, candidate number and name on all the work you hand in.
Write in dark blue or black pen.
You may use a soft pencil for any diagrams, graphs or rough working.
Do not use staples, paper clips, highlighters, glue or correction fluid.
DO NOT WRITE IN ANY BARCODES.

Answer **all** questions.
You may lose marks if you do not show your working or if you do not use appropriate units.
Take the weight of 1 kg to be 10 N (i.e. acceleration of free fall = 10 m/s^2).

At the end of the examination, fasten all your work securely together.
The number of marks is given in brackets [] at the end of each question or part question.

This document consists of **19** printed pages and **1** blank page.



- 1 A ball player bounces a ball of mass 0.60 kg. Its centre of mass moves down through a distance of 0.90 m, as shown in Fig. 1.1. Ignore air resistance throughout this question.

For
Examiner's
Use

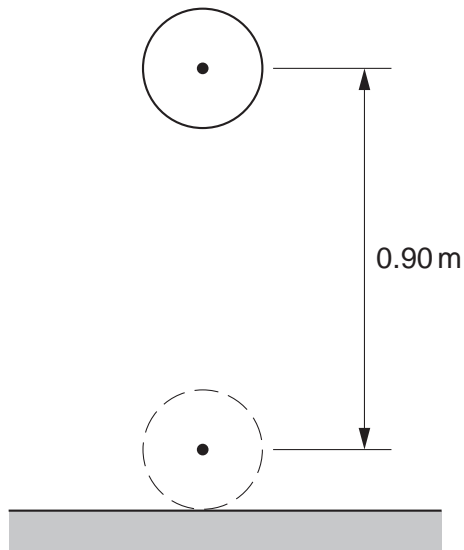

Fig. 1.1

- (a) Calculate the decrease in gravitational potential energy of the ball as it moves down through the 0.90 m.

decrease in PE = [2]

- (b) The ball hits the ground at 7.0 m/s.

Calculate the initial energy given to the ball by the player.

energy given = [3]

- (c) On another occasion, the player throws the ball into the air, to a height of 4.0m above the ground. The ball then falls to the ground.

For
Examiner's
Use

During the impact, 22% of the ball's energy is lost.

- (i) Suggest one reason why energy is lost during bouncing.

.....
..... [1]

- (ii) Calculate the height to which the ball rises after the bounce.

[2]

- (iii) An observer who sees the ball bounce says, "That ball should be slightly warmer after that bounce."

Explain why the observer's statement is true.

.....
.....
..... [1]

[Total: 9]

- 2 Four students, A, B, C and D, each have a spring. They measure the lengths of their springs when the springs are stretched by different loads.

Their results are shown in Fig. 2.1.

	student A	student B	student C	student D
load/N	spring length/cm	spring length/cm	spring length/cm	spring length/cm
0.5	6.7	9.2	9.1	10.0
1.0	7.7	10.0	9.9	11.1
1.5	8.7	10.8	10.7	12.2
2.0	9.7	11.6	11.5	13.3
2.5	10.7	12.6	12.3	14.4
3.0	11.7	13.8	13.1	15.5
3.5	12.7	15.2	13.9	16.6
4.0	13.7	16.8	14.7	17.7

Fig. 2.1

- (a) (i) State which student had loaded the spring beyond the limit of proportionality.

..... [1]

- (ii) Explain how you obtained your answer to (a)(i).

.....

 [2]

- (b) For the spring used by student A, calculate

- (i) the extra extension caused by each additional 0.5 N,

extra extension = [1]

- (ii) the unloaded length of the spring.

unloaded length = [1]

- (c) Student A obtains a second spring that is identical to his first spring. He hangs the two springs side by side, as shown in Fig. 2.2.

For
Examiner's
Use

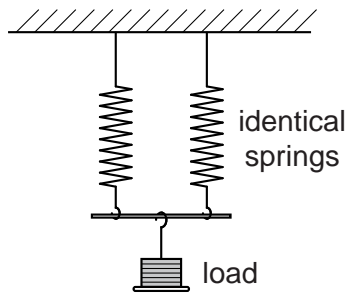

Fig. 2.2

Use the table to calculate the length of each of the springs when a load of 2.5 N is hung as shown in Fig. 2.2. Show your working.

length = [2]

[Total: 7]

- 3 An ornamental garden includes a small pond, which contains a pumped system that causes water to go up a pipe and then to run down a heap of rocks.

Fig. 3.1 shows a section through this water feature.

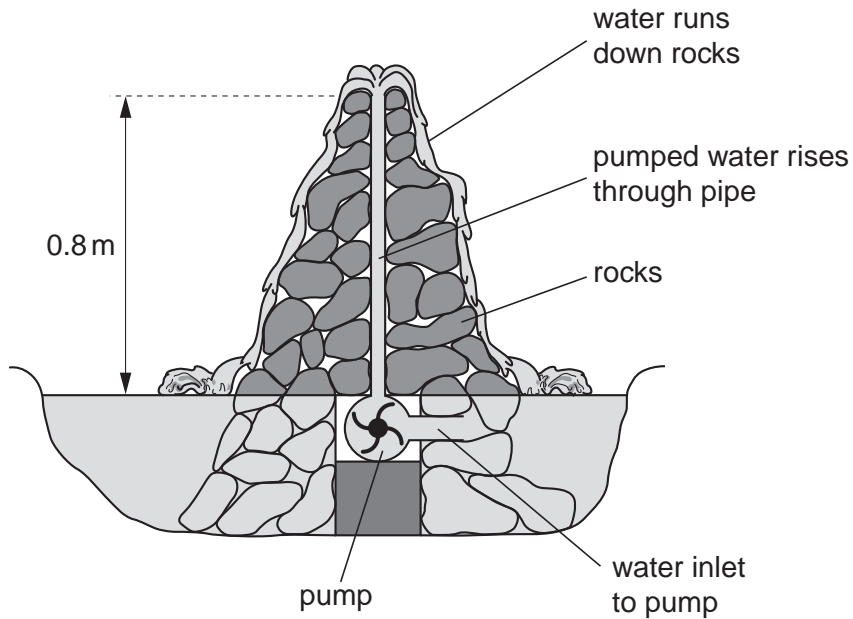

Fig. 3.1

The density of water is 1000 kg/m^3 . A volume of 1 litre is equal to 0.001 m^3 .

- (a) Calculate the mass of 1 litre of water.

mass = [2]

- (b) Calculate the work done raising 1 litre of water through a height of 0.8m.

work = [2]

- (c) The pump lifts 90 litres of water per minute.

Calculate the minimum power of the pump.

For
Examiner's
Use

power = [2]

- (d) The pump is switched off.

Immediately after the pump is switched off, what is the value of the water pressure at the bottom of the 0.8 m pipe, due to the water in the pipe?

pressure = [2]

[Total: 8]

4 A technician has been asked to design a liquid-in-glass thermometer, using alcohol as the liquid.

(a) (i) State what is meant by the *sensitivity* of the thermometer.

.....
..... [1]

(ii) State one design feature the technician could use in order to ensure a very sensitive thermometer.

.....
..... [1]

(b) (i) State what is meant by the *range* of the thermometer.

.....
..... [1]

(ii) State one design feature that would ensure that the thermometer measured the desired range of temperatures.

.....
..... [1]

(c) (i) State what is meant by *linearity*, as it applies to the thermometer.

.....
..... [1]

(ii) State one design feature that would ensure linearity in the technician's thermometer.

.....
..... [1]

[Total: 6]

- 5 The apparatus shown in Fig. 5.1 is used to demonstrate how a coin and a piece of paper fall when they are released from rest.

For
Examiner's
Use

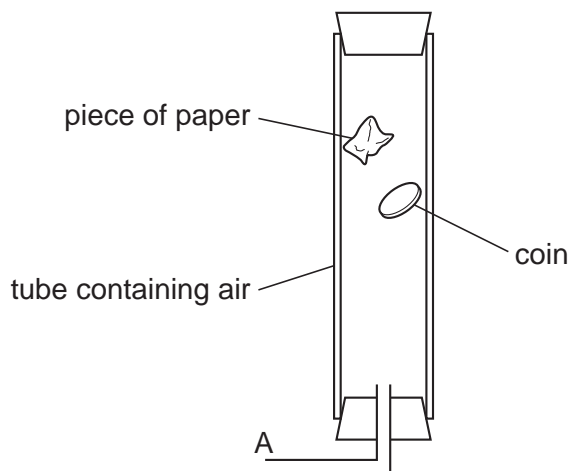

Fig. 5.1

- (a) At the positions shown in Fig. 5.1, the paper is descending at constant speed but the coin still accelerates.

In terms of the forces acting, explain these observations.

paper

.....

.....

coin

.....

..... [4]

- (b) A vacuum pump is now connected at A and the air in the tube is pumped out.

The paper and coin are again made to fall from rest.

State one difference that would be observed, compared with what was observed when air was present.

.....

..... [1]

[Total: 5]

6 A ray of monochromatic light passes through the glass prism shown in Fig. 6.1.

For
Examiner's
Use

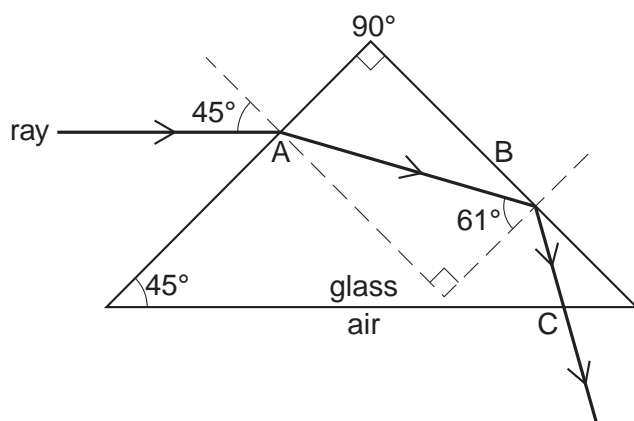

Fig. 6.1

(a) State what is meant by the term *monochromatic*.

.....
 [1]

(b) State the name given to what happens to the ray at A.

..... [1]

(c) Use the values on the diagram to calculate the angle of refraction at A (The angles in a triangle add up to 180°).

angle of refraction = [1]

(d) Calculate the refractive index of the glass.

refractive index = [3]

- (e) Explain why the ray does not emerge into the air at B, but does emerge at C.

For
Examiner's
Use

.....

.....

.....

..... [2]

- (f) An identical prism is stuck to the first prism using a transparent adhesive with the same refractive index as the glass. This is shown in Fig. 6.2.

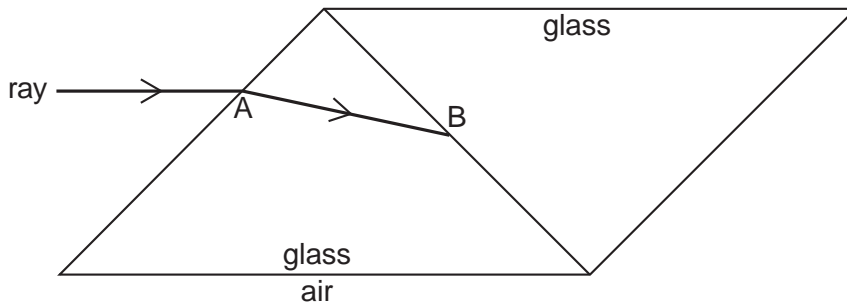

Fig. 6.2

On Fig. 6.2, draw the path of the ray after it has reached B and until it has passed into the air again. [3]

[Total: 11]

- 7 A disused railway line has a length of 300 m. A man puts his ear against one end of the rail and another man hits the other end of the rail and another man hits the other end with a metal hammer, as shown in Fig. 7.1.

For
Examiner's
Use

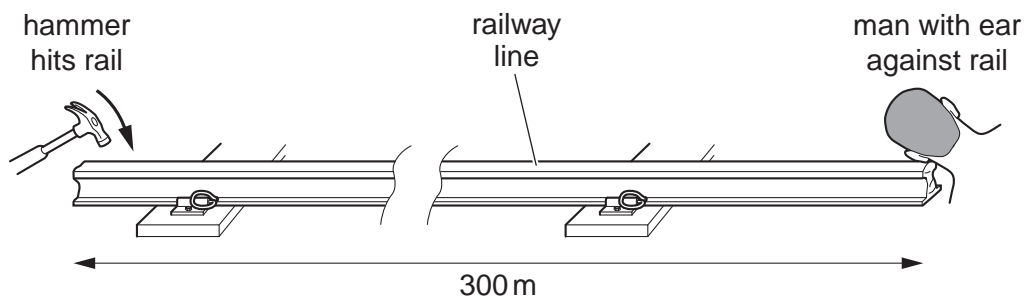

Fig. 7.1

- (a) (i) State an approximate value for the speed of sound in air.

..... [1]

- (ii) Sound travels at 5000 m/s in steel.

Calculate the time it takes for the sound to travel along the rail.

time taken = [2]

- (b) The man with his ear to the railway line actually hears two sounds from the hammer, separated by a short interval.

Explain why he hears two sounds.

.....

[2]

[Total: 5]

8 (a) State the law of attraction and repulsion between electrostatic charges.

.....

 [2]

(b) Sometimes, when people have been riding in a car, they get an electric shock from the door handle as they get out of the car.

Suggest why this happens.

.....

 [2]

(c) A plastic rod is rubbed with a cloth and becomes positively charged. After charging, the rod is held close to the suspended table-tennis ball shown in Fig. 8.1. The table-tennis ball is covered with metal paint and is initially uncharged.

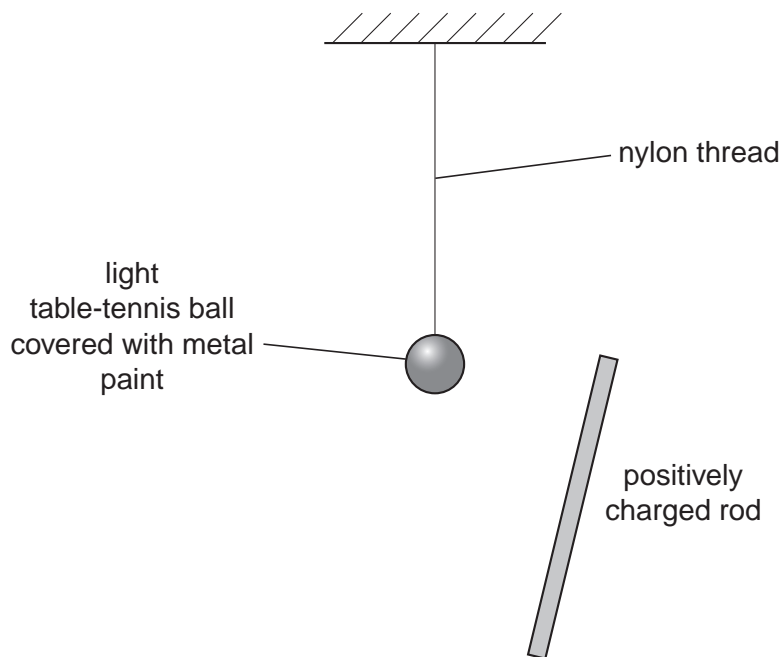

Fig. 8.1

(i) Describe what happens to the charges on the metal-painted table-tennis ball as the positively-charged rod is brought close to the ball.

.....

 [1]

(ii) The ball is attracted towards the charged rod.

Explain why this happens.

.....
.....
..... [2]

(iii) When it is a few centimetres away from the rod, the ball is briefly touched by a wire connected to earth.

In terms of the movement of charges, describe what happens to the charge on the ball.

.....
..... [2]

[Total: 9]

- 9 The circuit in Fig. 9.1 contains a 4.0V battery, whose resistance can be ignored. There are also three resistors, a 3-position switch, S, and another component, P.

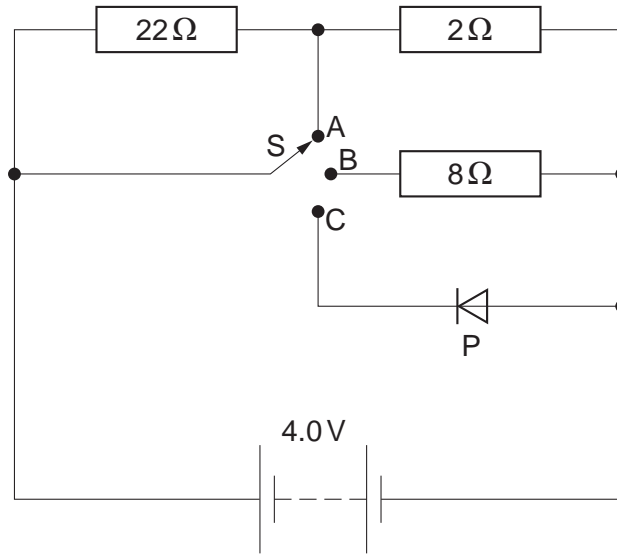

Fig. 9.1

- (a) State the name of component P.

..... [1]

- (b) Deduce the resistance of the circuit when switch S is connected to

- (i) point A,

resistance = [1]

- (ii) point B.

resistance = [3]

(c) State the current in component P when S is in position C, and explain your answer.

current =

explanation

.....

.....

..... [2]

(d) The 22Ω resistor is removed as shown in Fig. 9.2.

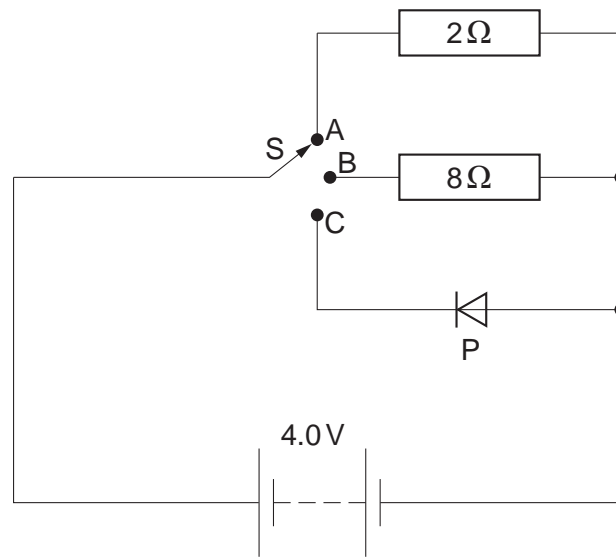

Fig. 9.2

Showing your working, decide which switch position will result in energy release from the circuit at the rate of 2.0W .

switch position = [3]

[Total: 10]

- 10 A student is using a cathode-ray oscilloscope to display the waveform of an alternating current supply. The arrangement is shown in Fig. 10.1.

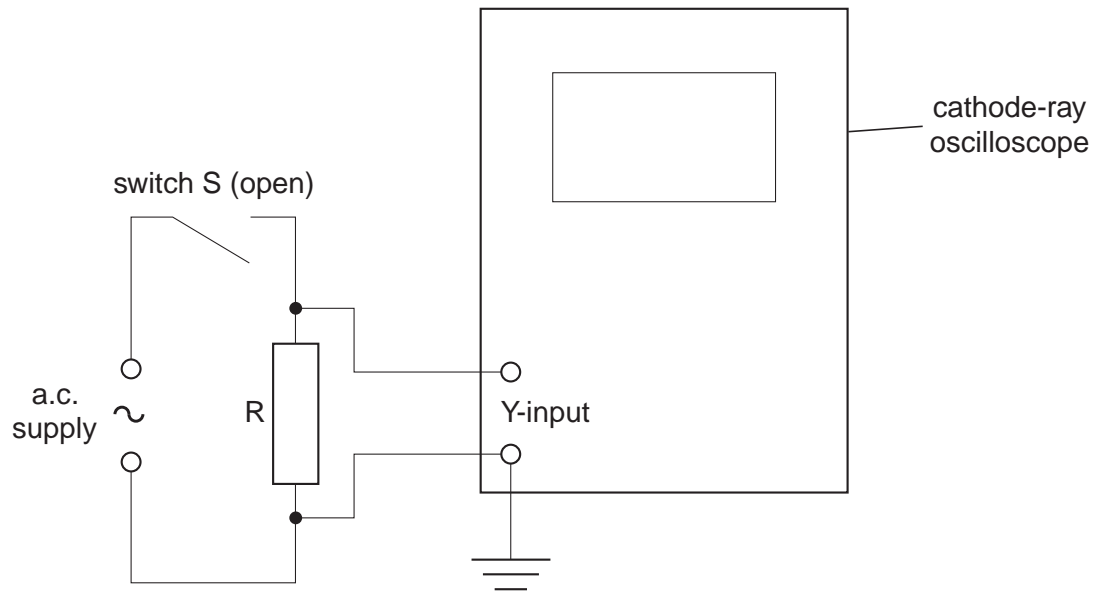

Fig. 10.1

When switch S is closed, the trace seen on the screen is as shown in Fig. 10.2. To get this trace, the settings of the oscilloscope controls are

volts/cm: 5V/cm

time-base: 10ms/cm

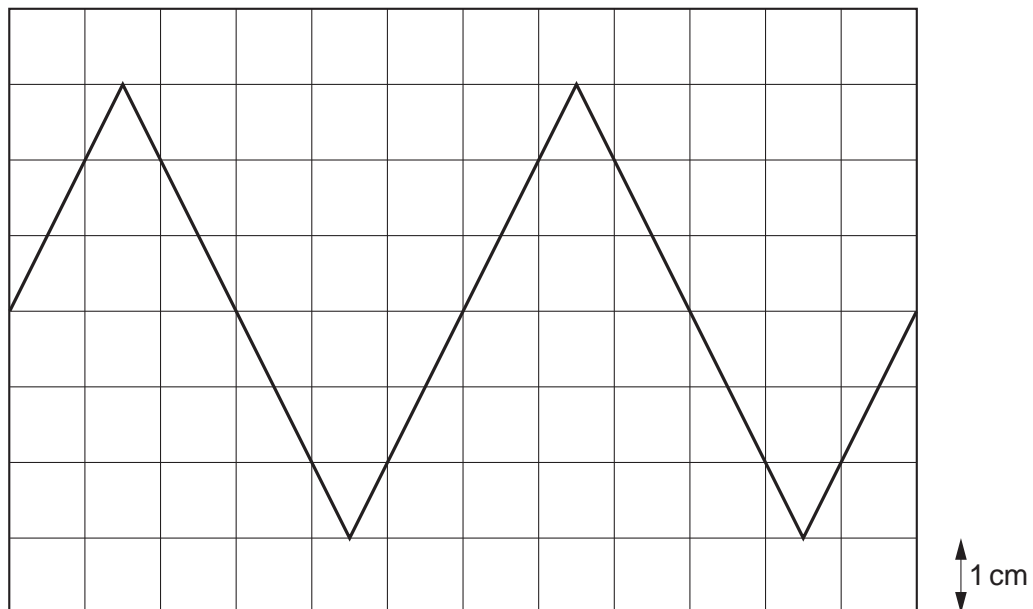

Fig. 10.2

- (a) On Fig. 10.2, carefully draw what is seen on the screen when the frequency of the supply is increased to 1.5 times its previous value. [3]

(b) What change, if any, must be made to the oscilloscope volts/cm and time-base controls in order to reduce the peak-to-peak height of the trace to half that shown in Fig. 10.2?

*For
Examiner's
Use*

volts/cm setting [2]

time-base setting [1]

[Total: 6]

- 11 A radium source emits α , β and γ radiations. Fig. 11.1 illustrates what happens to these radiations when they pass through a magnetic field. The left hand beam is actually deviated a great deal less than shown on Fig. 11.1.

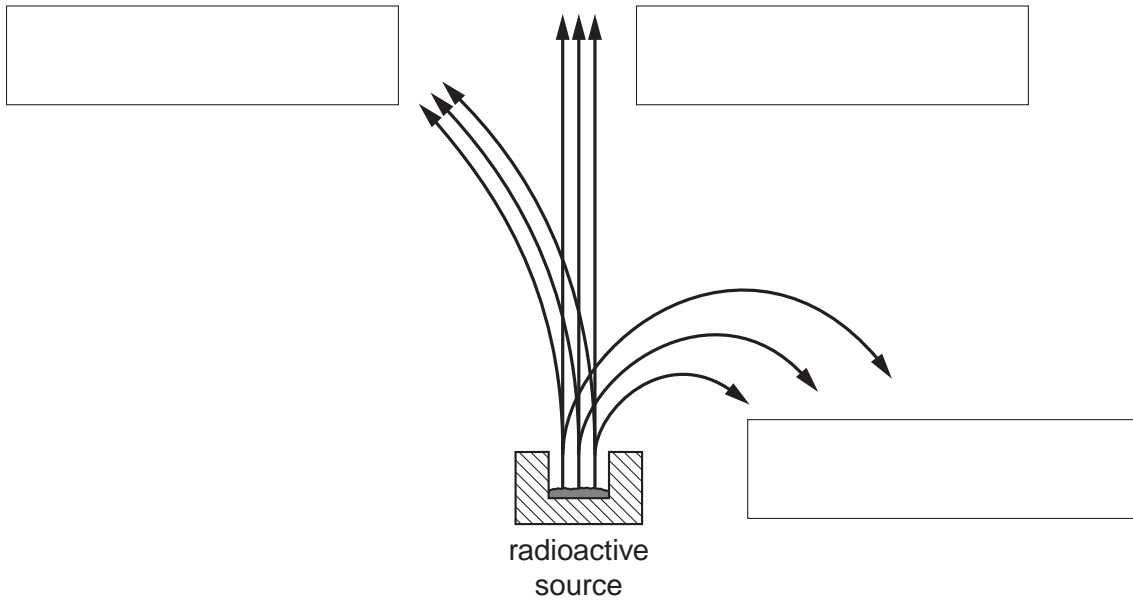

Fig. 11.1

- (a) On Fig. 11.1, label the three radiations by writing in the boxes provided. [2]
- (b) State the direction of the magnetic field that gives the deflections shown in Fig. 11.1.

..... [2]

[Total: 4]

Permission to reproduce items where third-party owned material protected by copyright is included has been sought and cleared where possible. Every reasonable effort has been made by the publisher (UCLES) to trace copyright holders, but if any items requiring clearance have unwittingly been included, the publisher will be pleased to make amends at the earliest possible opportunity.

University of Cambridge International Examinations is part of the Cambridge Assessment Group. Cambridge Assessment is the brand name of University of Cambridge Local Examinations Syndicate (UCLES), which is itself a department of the University of Cambridge.